

PACKAGING SIZES: 65" x 66" x 3-1/2"
 TOTAL SHIPPING WEIGHT: 100 LBS

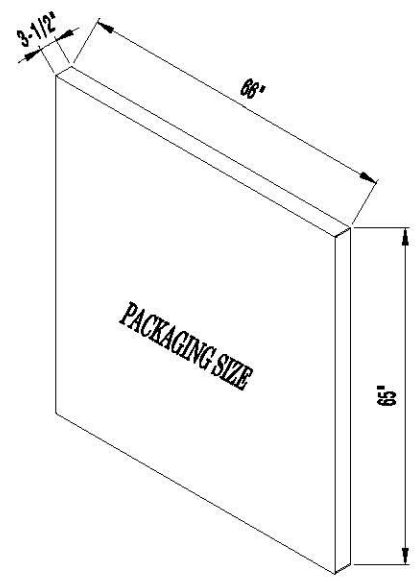

PREPERATION:

1. REMOVE BIKE RACK FROM ITS BOX AND BAGS, AND PLACE ON TOWELS OR OTHER SOFT SURFACE TO PREVENT SCRATCHING (TOWELS, CARDBOARD, GRASS, ECT.)

INSTALLATION: *IN-GROUND MOUNT*

1. USE THE BIKE RACK AS A QUIDE FOR FOOTING PLACEMENT.
2. PLACE THE BIKE RACK IN THE GROUND. MAKE SURE THE BIKE RACK IS LEVEL, WELL SUPPORTED AND AT THE CORRECT HEIGHT. USE SPECIAL CARE WHEN POSITIONING TO NOT DAMAGE THE FINISH OF THE BIKE RACK. PICK AND SET INTO POSITION.
3. ONCE BIKE RACK IS IN POSITION, POUR THE CONCRETE FOOTINGS.
4. THIS PRODUCT MUST BE PERMANENTLY AFFIXED IN THE GROUND. CONSULT YOUR LOCAL CODES FOR REGULATIONS
5. CURE AND HARDEN THE CONCRETE FOOTINGS ACCORDING TO CONCRETE CURING PROCEDURES.

NOTES:

1. DRAWINGS NOT TO SCALE. DO NOT SCALE DRAWINGS.
2. THIS PRODUCT IS SHIPPED FULLY ASSEMBLED.